

Technical data sheet

Product features



Pasta cooker

Model

SAP Code

00008183



- Basin volume [l]: 2 x 23
- Drain type: Trough the cabinet
- Safety drain: Yes
- Material: AISI 304 top plate and cladding
- Protection of controls: IP24
- Maximum device temperature [°C]: 110
- Number of baskets: 2

SAP Code	00008183	Power electric [kW]	15.000
Net Width [mm]	800	Loading	400 V / 3N - 50 Hz
Net Depth [mm]	730	Basin volume [l]	2 x 23
Net Height [mm]	900	Number of baskets	2
Net Weight [kg]	74.90		

Technical data sheet

Technical drawing



Pasta cooker

Model

SAP Code

00008183

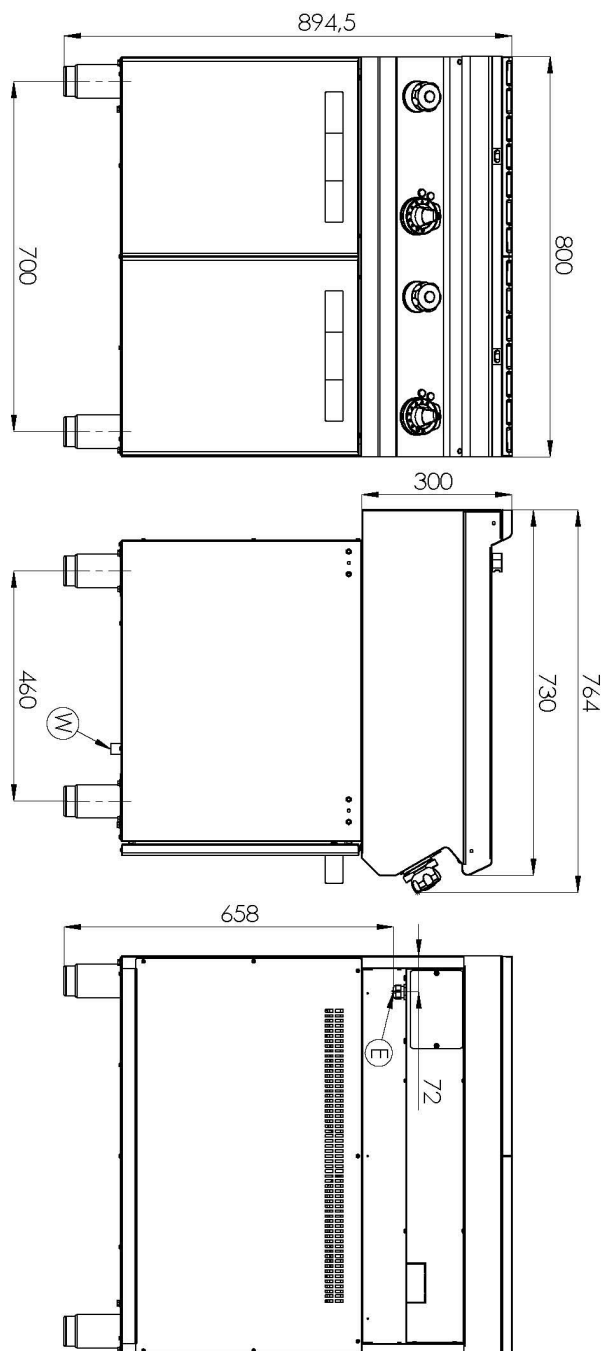

Technical data sheet

Technical parameters



Pasta cooker

Model

SAP Code

00008183

1. SAP Code:

00008183

2. Net Width [mm]:

800

3. Net Depth [mm]:

730

4. Net Height [mm]:

900

5. Net Weight [kg]:

74.90

6. Gross Width [mm]:

840

7. Gross depth [mm]:

800

8. Gross Height [mm]:

1080

9. Gross Weight [kg]:

85.00

10. Device type:

Electric unit

11. Construction type of device:

Stationary

12. Power electric [kW]:

15.000

13. Loading:

400 V / 3N - 50 Hz

14. Protection of controls:

IP24

15. Device color:

Stainless steel

16. Material:

AISI 304 top plate and cladding

17. Worktop type:

Molded - comfortable cleaning maintenance

18. Worktop material:

AISI 304

19. Surface finish:

polished stainless steel

20. Basin volume [l]:

2 x 23

21. Basin dimensions [mm x mm x mm]:

2 x 340 x 306 x 329

22. Device capacity [l]:

23.00

23. Maximum device temperature [°C]:

110

24. Minimum device temperature [°C]:

30

25. Service accessibility:

Trough the frontal panel

26. Safety thermostat:

Yes

27. Adjustable feet:

Yes

28. Heating element material:

Incoloy

Technical data sheet

Technical parameters



Pasta cooker

Model

SAP Code

00008183

29. Number of baskets:

2

30. Number of basins:

2

31. Basin material:

AISI 316 - Stainless steel highly resistant to salt water

32. Drain type:

Trough the cabinet

33. Safety drain:

Yes

34. Water supply connection:

Yes

35. Heating location:

Inside the tank